



RUBBER PARK INDIA (PVT) LTD
(A JV of KINFRA & Rubber Board)

2 A, "Kautileeyam", Rubber Park, Valayanchirangara, P.O, Ernakulam, Kerala-683 556.
Tel: (0484) 2657218/ 2655548 | Email: md@rubberparkindia.org | Web: www.rubberparkindia.org

Notice Inviting Tender (NIT)

Tender No : RP/E/T-06/R1/2024-2025

Name of the Work : Supply, installation, testing and commissioning of LT MCC Panel with Fabricated stand for Pump House including buyback for existing old panel at Rubber Park India (P) Ltd., Irapuram.

EMD : Rs. 6, 100/-

Period of Completion : 60 days

Tender Fee : Rs.600/- (Including GST)



RUBBER PARK INDIA (PVT) LTD
(A JV of KINFRA & Rubber Board)

2 A, "Kautileeyam", Rubber Park, Valayanchirangara, P.O, Ernakulam, Kerala-683 556.
Tel: (0484) 2657218/ 2655548 | Email: md@rubberparkindia.org | Web: www.rubberparkindia.org

Tender No : RP/E/T-06/R1/2024-2025

Name of Work : Supply, installation, testing and commissioning of LT MCC Panel with Fabricated stand for Pump House including buyback for existing old panel at Rubber Park India (P) Ltd., Irapuram

Locality : Rubber Park India (P) Ltd., Irapuram, Valayanchirangara P O, Ernakulam- 683 556.

Last date of Submission : 29/01/2025 at 2:00 PM

Name of Bidder :

Address of Bidder :

.....

.....

INDEX

SI No	Details	Pages
1.	Re Tender Notice	4
2.	Notice Inviting Re-Tender (NIT)	5-9
3.	Bid forms & other forms	18-26
4.	Price Part	27-28

Re Tender Notice



**Rubber Park India (P) Ltd. (RPIPL), Irapuram
Valayanchirangara P O, Ernakulam- 683 556**

Rubber Park India (P) Ltd. (RPIPL) invites sealed, unconditional item rate tenders from registered and competent manufacturers/dealers/suppliers/firms for the following work:

Supply, installation, testing and commissioning of LT MCC Panel with Fabricated stand for Pump House including buyback for existing old panel at Rubber Park India (P) Ltd., Irapuram

Tender fee	EMD	Last Date of submission
Rs.600/- (Inclusive of GST)	Rs.6, 100/-	29/01/2025 at 2:00 PM

Tender document (Non-transferable) can be downloaded from the website, www.rubberparkindia.org. Enquires can be made from the office of Rubber Park India (P) Ltd., Irapuram, Ernakulam (Tel: 0484 2657218/2655538), from 20/01/2025 to 29/01/2025 .

**Place: Irapuram
Date: 20/01/2025**

Sd/-
**Managing Director
Rubber Park India (P) Ltd.**

Notice Inviting Re-Tender

Rubber Park India (P) Ltd. (RPIPL) invites sealed, unconditional item rate tenders, from registered and competent manufacturers/dealers/suppliers/firms for the following work of “Supply, installation, testing and commissioning of LT MCC Panel with Fabricated stand for Pump House including buyback for existing old panel at Rubber Park India (P) Ltd., Irapuram”, who has to fulfil the eligibility criteria prescribed hereunder.

NIT No.	Name of work & Location	EMD (Rs.)	Period of completion	Last date of submission of Tender document	Time & Date of opening of Technical bid	Tender Fee (Rs.)
RP/E/T-06/R/1/2024-2025	Supply, installation, testing and commissioning of LT MCC Panel with Fabricated stand for Pump House including buyback for existing old panel at Rubber Park India (P) Ltd., Irapuram	6, 100	60 days	29/01/2025 at 2.00PM	29/01/2025 at 3.00PM	600/- (Inc.GST)

1. **Eligibility Criteria:**

Bidders who fulfil the following requirement shall be eligible to apply.

- a. The bidder shall have a valid Class B or above contract license supplied by KSELB.
 - b. The Panel shall have CPRI type test certificate for short circuit rating, temperature rise and IP classification for similar panels.
 - c. The Bidder shall have valid GST registration.
2. The time for completing the work shall be 60 days from the date of issue of work order. The materials shall be delivered at Rubber Park located at Irapuram Village in Kunnathunadu Taluk of Ernakulam District in Kerala State.
3. *Tender document can be download from the official website of RPIPL, www.rubberparkindia.org Enquires can be made from the office of Rubber Park India (P) Ltd., Irapuram, Ernakulam (Tel: 0484 2657218/2655538), from 20/01/2025 to 29/01/2025 .*

4. Documents to be submitted: -
- (i) The bidders shall submit proof of contractor license issued by KSELB.
 - (ii) The bidders shall submit proof of CPRI type test certificate of the panel for short circuit rating, temperature rise and IP classification for similar panels.
 - (iii) The bidders shall submit the copy of GST registration.
 - (iv) The bidders shall submit the tender document duly filled and signed on all pages.
 - (v) The bidders shall submit the DD or payment receipt for EMD and Tender fee.
 - (vi) Price Bid duly filled and signed.
5. *Tender Submission: Tender shall be submitted in sealed envelope, duly super scribed "Supply, installation, testing and commissioning of LT MCC Panel with Fabricated stand for Pump House including buyback for existing old panel at Rubber Park India (P) Ltd., Irapuram." with the tender fee (Rs. 600/-) and EMD (Rs. 6100/-) as Demand Draft in favour of Managing Director, Rubber Park India (P) Ltd., payable at Ernakulam. This sealed cover shall be addressed to The Managing Director, Rubber Park India (P) Ltd.*
- The tender in the prescribed format along with Tender fee, EMD and other required details, in sealed cover should reach Rubber Park India (P) Ltd, 2A Kautileeyam, Valayanchirangara, Ernakulam 683 556 on or before 29/01/2025 , 2.00 PM.
6. *The bid submitted will be opened on 29/01/2025 at 03.00 PM in the office of Rubber Park India (P) Ltd, 2A Kautileeyam, Valayanchirangara, Ernakulam 683 556.*
7. *Earnest Money Deposit (EMD) of the unsuccessful bidders will be refunded without any interest on finalization of the contract with the successful bidder.*
8. *EMD deposited with the client will be forfeited / encashed under the following circumstances.*
- *If the bidder withdraws his bid during the firm period specified.*
 - *If the successful bidder fails within the time limit to sign the contract agreement or fails to furnish the required performance security deposit.*
9. The bid submitted is treated as invalid if the bidder does not submit all the documents (as stipulated in the bid document).
10. The Managing Director, Rubber Park India (P) Ltd., does not bind itself to accept the lowest or any other bid and reserves to itself to accept the lowest or any other bid and reserves to itself the authority to reject any or all the bids received without the

assignment of any reason. All bids in which any of the prescribed condition is not fulfilled or any condition including that of conditional rebate is put forth by the bidders shall be summarily rejected.

11. Canvassing whether directly or indirectly, in connection with bidders is strictly prohibited and the bids submitted by the contractors who resort to canvassing will be liable for rejection.
12. The Managing Director, Rubber Park India (P) Ltd., reserves to himself the right of accepting the whole or any part of the bid and the bidders shall be bound to perform the same at the rate quoted.
13. The contractor shall not be permitted to bid for supply if he/she is the near relative of an officer of Rubber Park India (P) Ltd.
14. The bid for the work shall remain open for acceptance for a period of 45 days from the date of opening of bids. If any bidder withdraws his bid before the said period or issue of Work order, whichever is earlier, or makes any modifications in the terms and conditions of the bid which are not acceptable to Rubber Park India (P) Ltd., then Rubber Park India (P) Ltd. shall, without prejudice to any other right or remedy, be at liberty to forfeit 100% of the said earnest money as aforesaid. Further the bidders shall not be allowed to participate in the rebidding process of the Work and will be blacklisted.
15. The intending bidders shall ensure that the equipment offered are fully met with the technical specifications mentioned in the tender.
16. The intending bidders have to quote their corresponding item rates in schedule of quantities along with the price bid. The quoted price will be considered as all-inclusive rate inclusive of cost of transportation, packing, freight and insurance charges, all overheads, contingencies, profits, taxes (ie. Income tax etc.), duties/ levies, loading and unloading charges etc. for supply, installation, testing and commissioning of the equipment at the site of Rubber Park India (P) Ltd, Irapuram, but only exclusive of GST. The rates quoted by the Contractor shall be firm throughout the contract period and there shall be no upward revision of the rates quoted by the Contractor for any reasons whatsoever.
17. The successful bidder on receipt of the Work Order, shall deposit an amount equal to 5 % (Five percent) of the contract value, as Performance Guarantee in the form of DD in favor of **the Managing Director, Rubber Park India (P) Ltd. payable at Valayanchirangara** or online transfer to the account (**Account No. 57042660807, Name of Account holder: Rubber Park India (P) Ltd., Bank & Branch: State Bank of**

India, Valayanchirangara., IFSC Code: SBIN0070558) within 7 days from the date of Work order/letter of award and the deposit will be retained till 90 days after the expiry of the warrantee period/Defect liability Period. On completion of warrantee Period, the Engineer-in-Charge of Rubber Park shall recommend on demand from the bidder/Contractor to refund to him the Performance Guarantee and the same will be refunded/ released by the Accepting Authority provided that the Engineer-in- Charge is satisfied that there is no defect/liability outstanding against the bidder/contractor. All the deposits of EMD, security deposit / performance guarantee will not bear any interest whatsoever.

18. The successful bidder should provide warranty for 12 months from the date of supply, installation, testing, commissioning and handing over to the Engineer in charge of the work. The bidder should submit the warranty certificate along with the equipment in favour of the Managing Director - Rubber Park India (P) Ltd.
19. The successful bidders / contractor, on acceptance of his bid by the Accepting Authority shall within 7 days from the date of work order/letter of award, sign the contract in Rs. 200 worth Kerala Stamp paper consisting of the notice Inviting Bid, all the documents including additional conditions, specifications and drawings, if any, form part of the bid and the rates quoted at the time of submission of bid and acceptance thereof together with any correspondence leading thereto.
20. If the successful bidder fails to complete the work on or before the contract, he shall, without prejudice to any other right or remedy available under the law to the Government on account of such breach, pay as agreed compensation the amount calculated at the rates 1% per week or part of the week on the total contract value of the order subject to a maximum of 10% of the contract value. The successful bidder shall not be liable for delays in performing his obligations resulting from any force majeure cause as referred to and/or defined below.

Force majeure is herein defined as any cause which is beyond the control of the Contractor or the Employer as the case may be, which they could not foresee or with a reasonable amount of diligence could not have foreseen and which substantially affects the performance of the Contract, such as:

- a. Natural phenomena, including but not limited to floods, droughts, earthquakes and epidemics;
- b. Acts of any Government, domestic or foreign, including but not limited to war, declared or undeclared, priorities, guarantees, embargoes.

Then upon the happening of any such event causing delay, the contractor shall within

07 days give notice thereof in writing to the authority, but shall nevertheless use constantly his best endeavors to prevent or make good the delay and shall do all that may be reasonably required to the satisfaction of Rubber Park India (P) Ltd, to proceed with the work.

21. Payment Terms for Supply & Installation

Payment shall be released within 15 days after successful completion of the supply, installation, testing and commissioning and handing over of the total item against the submission of the factory test report, routine test report and GST invoice. The GST portion of the invoice would be released only after reflection of GST amount in our GSTR 2B.

Annexure-1: Technical Specification for MCC Panel for 30 HP Pump

All switchgears shall be fully rated at an ambient temperature of 40°C. All the switch boards are to be factory assembled, fabricated by a firm having CPRI type test certificate for short circuit rating, temperature rise and IP classification for similar panels.

A. Scope of work

Supply installation testing and commissioning of LT Panel, cubicle type, made out of 2mm thick CRCA sheet, totally enclosed, IP 42, free standing, floor mounting, dust and vermin proof, indoor, compartmentalised, suitable for operation on 3 phase, 415 V, 50Hz AC system with busbars, including internal wiring with suitable size HFFR wires/cable, interconnection, duly powder coated with seven tank process etc. The panel shall be fabricated from a firm having CPRI certification with test certificates for similar panel (required for short circuit rating, temperature rise and IP classification) and with following switchgears, metering instruments and accessories etc. complete as required as per drawing & specification. Incomer- 125 A, FP 36kA, MCCB with thermal based adjustable release with OL & SC protection - 1 No. Instruments (0 to 500) V, Voltmeter for 3 phase 4 wire operation with selector switch , (0-125)A ammeter for 3 phase , Resin cast CT (125/5, 0.5s), 2A SP MCB , LED indication lamps - RYB etc., as required complete as per Single Line Diagram. Busbar- 125A TPN busbar chamber with Aluminium busbar, Outgoings- 50 A TP MPCB - 3 Nos, STAR DELTA STARTER for 3 phase, 50Hz motor of 30 HP capacity with ON/OFF LED Indication lamps, Start / Stop push buttons, TP OLR with SPP, TP AC3 duty contactors, Auto/manual selector switch, contactor for A/M etc. - 2 Nos, 32A, 25 kA, 4P MCCB with ROM and spreader Terminal- 1 No. as outgoing and Space provision for one number of spare star delta starter for 3 phase, 50Hz motor of 30 HP capacity. The panel shall be with top/bottom entry to receive incoming & outgoing cable, all necessary interconnection & accessories as per particular specification & single line diagram. The panel shall be floor mounting with Fabricated metal stand of dimension 500 X700 mm (HXW). The scope is inclusive of the cost of all materials, dismantling of existing panels at pump house, consumables, labour, hire charges for all machinery, transportation,

insurance charges, all overheads, contingencies, profits, taxes (ie. Income tax etc.), duties/ levies, loading and unloading charges etc. complete as per the direction of Engineer in Charge. (Excluding GST).

B. Switch Board Construction

The switch boards are to be manufactured / assembled as per the latest BIS/IEC specifications, IP42 classification for indoor duty. The panel shall be floor mounted, free-standing type, suitable for indoor installation in dust, vermin proof construction and extensible type. The design shall include all provisions for safety of operation and maintenance personnel. The general construction shall conform to IEC 61439.

C. Housing Details

The Switch Board shall be fabricated out of 14 SWG (2mm) CRCA sheet for frame and 1.5mm for door and internal partitions (except load bearing members). It shall be provided with hinged doors on the front with necessary handles and earthed using flexible copper conductor. The doors shall be provided with neoprene gaskets. Suitable channel base frame should be provided for the panel board. Detachable gland plates of 3mm thick shall be provided at the bottom and top of the cable chamber, suitable for the termination of cables with compression type glands to the sizes as specified. Adequate space should be provided in the cable chamber for safe bending and termination of runs of cables and size as required. The enclosure shall be provided with lifting hooks, supporting legs and double earth terminals with double washers. The switch board shall be in cubicle design (each feeder components are housed in individual cubicle) and fully compartmentalized having total segregation between each cubicle. Suitable cable and busbar alleys shall be provided. All components of the switch board shall be approachable from front. The Busbar chamber cover should be bolted type. Supporting arrangement for dressing of power and control cables in cable alleys also shall be provided. The front openable/lockable door shall act as a cover for the switch boards. When door is open no live parts are accessible from the front door open case. The busbar should be extendable at both ends. No busbar should be protruded in the cable alley. General construction shall employ the principle of compartmentalization and segregation for each circuit. Unless otherwise approved, incomer and bus section panels or sections shall be separate and independent and shall not be mixed with sections required for feeders. Overall height of the panel shall not exceed 2.4 meters. The general arrangement and design of panels shall be got approved by RPIPL before fabrication. Cable entries for various feeders shall be from bottom. All cable terminations shall be through gland plates. There shall be separate gland plate for each cable entry so that there will not be dislocation of already wired circuits when new feeders are added. Cable entry plates shall therefore be sectionalized. The construction shall include necessary cable supports for clamping the cable in the cable alley or rear cable chamber. Necessary Eye bolt shall be designed and provided in the panel to take the dead load and dynamic loads during the unloading of the panels.

D. Powder coating

All metal sheets shall undergo 7 tank metal treatment for CPRI approved panel thorough degreasing, water rinse, de rusting, water rinse, phosphating, water rinse and then passivation. All metal surfaces shall be thoroughly cleaned and degreased to remove all scales, rust, grease and dirt. Fabricated structures shall be pickled and treated to remove any trace of acid. The undersurface shall be made free from all imperfections before undertaking powder coating. The colour of the Panel shall be colour of paint light Gray to shade RAL 7035; however, the contractor shall obtain details of approved colour from the Engineer-in-charge before powder coating. Panel finish shall be free from imperfections like pin holes, orange peels, run-off paint, etc. All unpainted steel parts shall be cadmium plated or suitably treated to prevent rust, corrosion, etc.

E. Busbar sizing connection and supports:

The busbars shall be made from high conductivity electrolytic grade aluminium alloy conforming to IS 5082. The busbars and supports shall be capable of withstanding the rated and short circuit current as per the single line diagram/ feeder details. Minimum size of main power bus bars shall be of incomer switch rating. Maximum current density permissible for Aluminium bus bars shall be 0.8 Amps/ 1 Sq.mm of bar without considering derating factors. An earthing busbar size shall be suitable for withstanding the fault current (6 MVA, 8 kA) and minimum 150 sq.mm section copper shall be provided outside panel at bottom throughout the length of the panel. All connections to individual circuits from the bus bar shall preferably be solid connections. The busbars shall be provided with heat shrinkable PVC insulating sleeve. Supports for busbars shall be made of suitable size cast resin ribbed insulators or SMC/DMC solid block type base and these should be adequate in number so as to avoid any sag in the busbars. (Hylam supports may not be used). Minimum clearance between phase to phase shall be as per IS/IEC standards. The entire panel shall have a common earth bar of size as specified with two terminals for earth connections.

F. Power Connection

For incoming and outgoing feeders of the switch boards, Aluminium conductor cable will be used and hence the panel has to be designed for receiving these and wherever required cable boxes shall be provided in panel by removable gland plates and shall be provided on top/bottom of panel, for cable entries. Adequate cable termination facility shall be made in the panel boards to terminate required runs and size of cables. To prevent accidental contacts, all interconnecting cables/ busbars and all terminals also shall be shrouded. Provision for clamping the cables inside the cable alley should be provided. Standard colour code of red, yellow and blue for phases and black for Neutral to be followed for all busbars/conductors.

G. Auxiliary wiring and Terminals

Wiring for all controls, protection, metering, signalling, etc. inside the switchboard shall be done with 650 volts grey colour minimum 1.5sqmm HFFR (Halogen free fire retardant) copper conductor cables except CT wiring. The CT wiring shall be done with minimum 2.5 sq mm wires with colour code. Control wiring to components fixed on doors shall be flexible type.

Wiring shall be suitably protected within switch board. Runs of wires shall be neatly bunched, suitably supported and clamped. All control wiring meant for external connections are to be brought out of terminal board. All control wiring should be provided with necessary cable sockets/ lugs at both ends. Conductors shall be terminated using compression type lugs. Each termination shall be identified at both the ends by PVC ferrules.

H. Component of switch boards

The panel shall be provided with 1 number of 125A MCCB, 2 Nos of 50A MPCBs, 4 numbers of 125/5A 0.5s class, CTs, 2 sets of star delta starter, instrument meters, Fabricated metal stand of dimension 500 X700 mm (HXW), etc. complete. The switch gears should be positioned inside the panel board as per manufacturers standards. For the star delta starter, three Nos. TP contactors suitable for AC-3 duty, bimetallic or other type of single-phase preventing type overload protection relay/inbuilt overload protection relay on MPCB in each type of starter and electronic timer in star delta starter. Bimetallic overload relays shall be with 3 elements, positive acting, ambient temperature compensated, time lagged, single phase preventing, hand reset type with adjustable settings. Unless specified otherwise elsewhere, each starter shall have start, stop, and reset, push buttons, On/OFF trip indicating lamps. Ammeter with ammeter selector switch to read motor line current shall be provided wherever specified, control circuit wired up to terminal for remote operation and power terminals to connect motor cables shall be provided.

I. Capacitors

Standard: IS 13340, IEC 60831

Rated voltage: 415V 50Hz

Type: APP Heavy duty Maximum Loss in watts: < 0.2 W/kVAr

Permissible over voltage: 10%

Capacitor should be of heavy duty all poly propylene type. All capacitors shall be of loss less than 0.5 W / kVAr, suitable to withstand + 10% voltage variation and rated for operating temperature up to 700C. Capacitor units shall be provided of rating specified in SOQ with externally mounted discharge resistors to reduce the residual voltage to less than 50 volts in one minute of switching off. Each capacitor unit shall be capable of operating continuously at 10% over voltage over and above the rated RMS voltage. The capacitor used shall be able to deliver kVAr mentioned in SOQ with 7% detuned reactors and 415V rated voltage.

J. Contactors

Contactors shall comply with IS 13947 and IS/IEC 60947 for general rules and standards pertaining to contactors and motor starters. The contactor shall be capable of withstanding breaking & making capacities per following: for capacitor switching should be of capacitor duty type (AC6B) with provision for reducing inrush current through a resistor, which closes prior to closing of the main contact.

K. Push Buttons

- 1 Type: Manually operated spring return type.
- 2 Standard applicable: IEC947-5-1
- 3 Electric Shock protection: Class 2 (IEC 536)
- 4 Degrees of protection: IP65
- 5 Diameter: 22mm
- 6 Type of mounting: snap type
- 7 Colour of actuator: Start PB - Green Stop PB - Red Test/Reset PB - Black
- 8 Contact configuration: 2NO+2NC.

L. Earthing

Two independent earthing points shall be provided outside the panel near bottom and these shall be inter-connected with Cu earthing busbars of minimum size 50 x 6 mm. All earthing points inside the distribution board shall be interconnected to these earthing points with copper conductor suitable for withstanding the fault current of 8 kA.

M. Name plates

Switch board/distribution board shall be provided with danger plate and name plates for all incoming and outgoing feeders. These name plates shall be of PVC (blue colour base & white letters engraved) screwed to panel. The size of each letters shall be 15mm x 10mm for Panel Board Identification name and remaining details shall be appropriate size and it shall be clearly visible from 1.5 meter away from the panel. PVC identification ferrule numbers shall be used for all internal wiring. The name plate shall contain the following information.

- ❖ Panel Board Identification name & number
- ❖ Feeder name.
- ❖ Switch/ fuse rating.
- ❖ Cable size.
- ❖ Feeder Cable from / To.....
- ❖ CT Ratio

N. Supports

Busbars shall be rigidly fixed to the supports, of SMC/DMC solid block type base. Busbars shall be firmly held within the slots in sheet type supports, which in turn shall be rigidly fixed to the chamber.

O. Factory Acceptance Tests and Routine tests:

The bidder shall submit type test certificates for similar panels, demonstrating compliance with short circuit rating, temperature rise, and IP classification requirements. The contractor must obtain prior approval of all drawings from the client before commencing fabrication works. All routine tests, as per relevant IS/IEC standards, shall be conducted on the panels. The client reserves the right to inspect the progress of work, assess the quality of materials used and workmanship, and witness the routine tests upon completion at the manufacturer’s premises. The contractor shall secure dispatch clearance from the client after the successful completion of routine tests. The contractor shall give at least 07 days advance information to RPIPL about the manufacturing and Routine tests plan.

P. List of Approved Make

Sl. No.	Item description	Approved Makes
1	MCCB	Schneider (Compact NSX), L&T (D SINE), ABB (T max), Siemens (3VL)
2	Capacitor	L&T, Sprague, Schneider, Epcos, Shreem, ABB
3	Starters, Timer & Contactors	Siemens, L&T, Schneider, C&S, ABB
4	Push Buttons	Schneider, Siemens, L&T, BCH, C&S, Teknic
5	Indicating lamps (LED type)	Teknic, Schneider, Siemens, L&T, BCH, C&S
6	Indicating meters	AE, MECO, L&T, Rishab
7	Current Transformer	AE, Intrans, Kappa, L&T, Rishab, ResiTech Electricals, PGR Powertech
8	660/1100 Volt grade stranded unsheathed wire with copper conductor	Finolex, RR Kabel, Lapp Kabel, Polycab, V-guard

Q. Single diagram & Physical layout of proposed MCC Panel (Tender Drawing No. RP/E/T-06/2024-25/DWG-01)

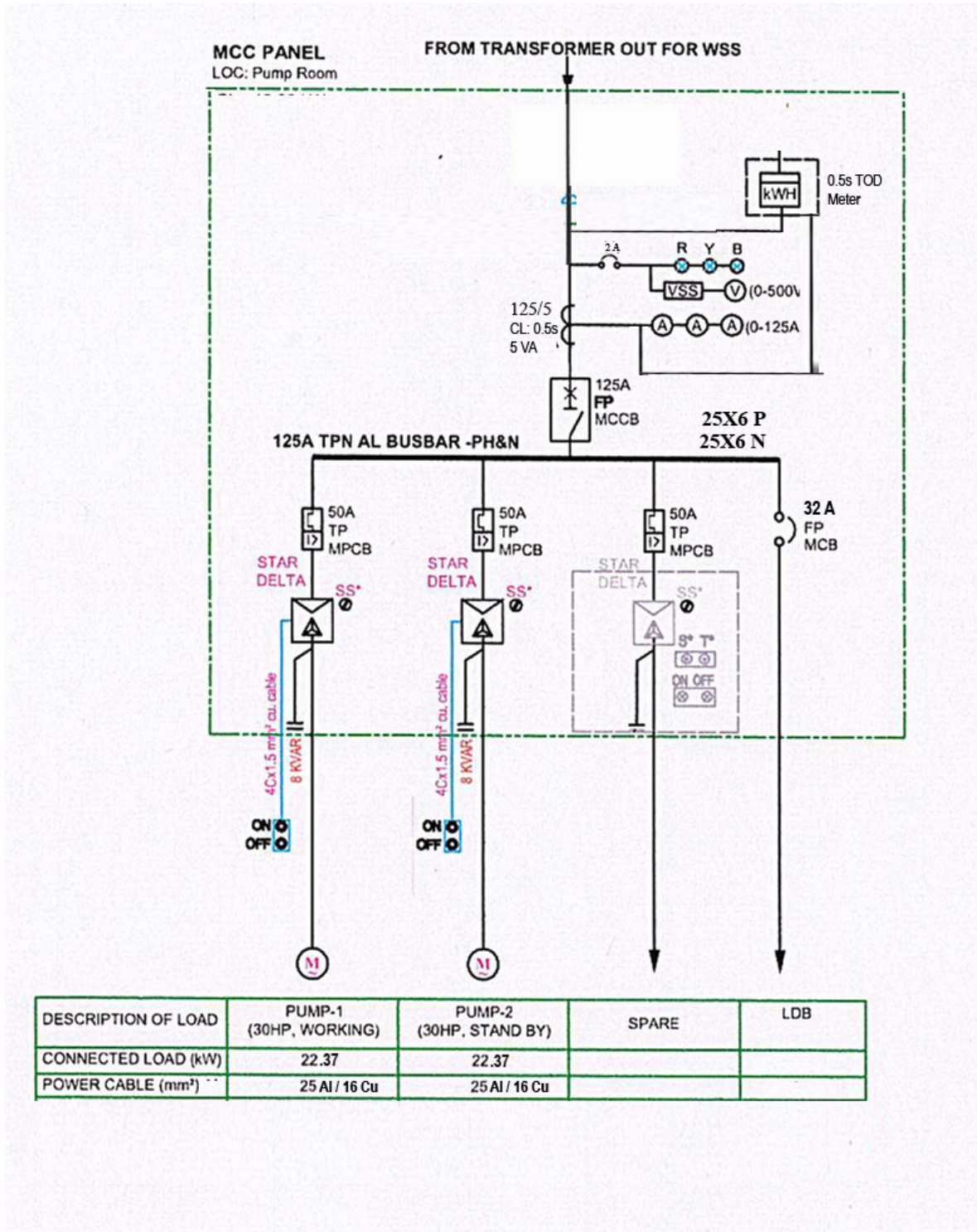

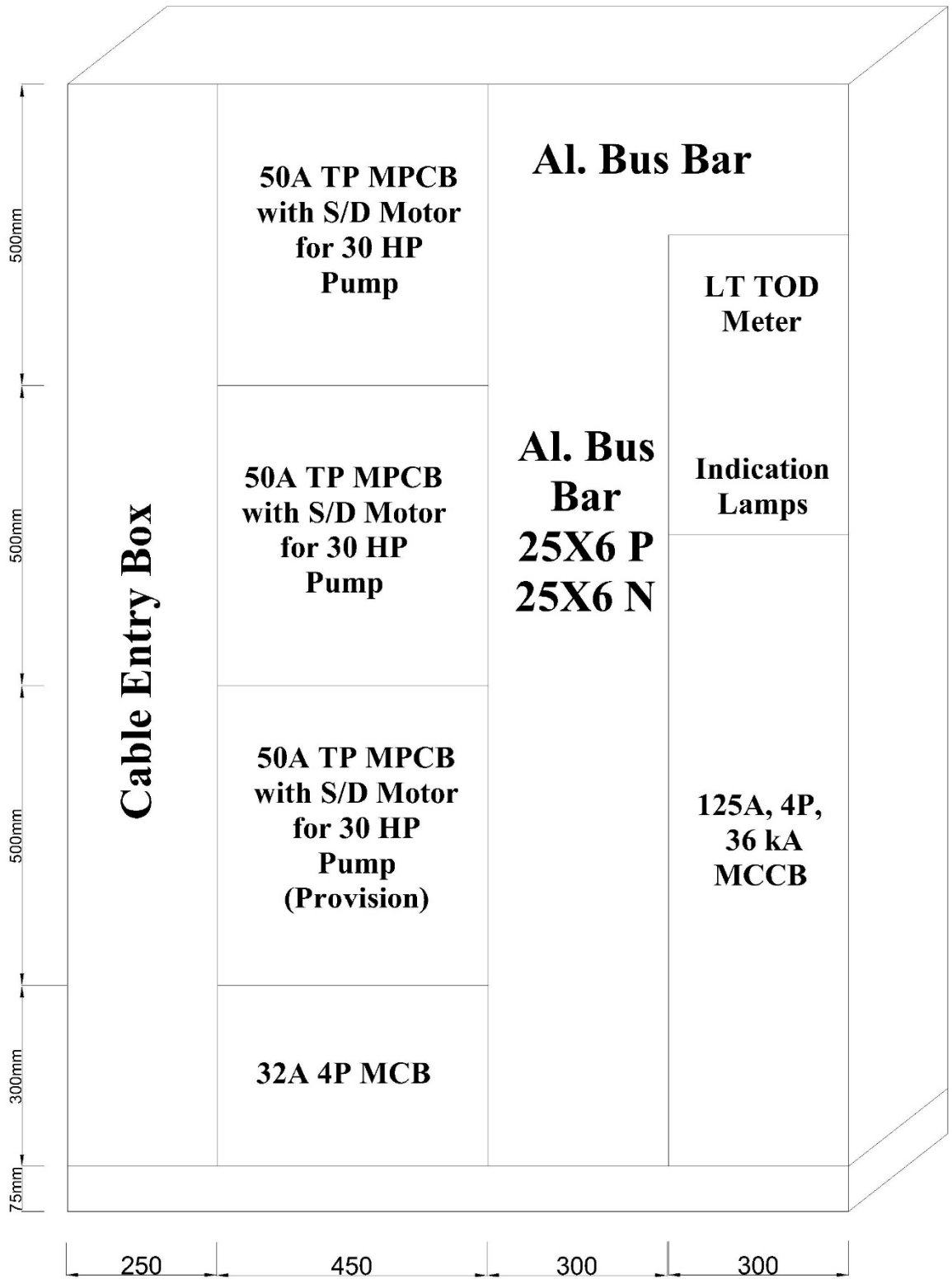

List of Documents to be submitted in sealed Envelope:

1. Signed Tender document
2. Duly signed bid forms and other forms (Note: Form-2 in Rs. 200 Stamp Paper)
3. EMD and tender fee
4. Certificate of Registration for GST.
5. Copy of Contractor license issued by KSELB.
6. Copy of CPRI test certificate for similar panels.
7. Signed BoQ (Price Part)

BID FORMS & OTHER FORMS

Form-1

DETAILS OF THE BIDDER

Name of the Work: Supply, installation, testing and commissioning of LT MCC Panel with Fabricated stand for Pump House including buyback for existing old panel at Rubber Park India (P) Ltd., Irapuram		
1. Details of the Bidder		
1.1	Name of the Firm/Bidder	
1.2	Address	
	Tel. No. (O)	
	Mob. No	
	E mail	
1.3	Nature of Firm (Note: - 1. Tick whichever is applicable. 2. Attach certified documentary proof)	Proprietary Partnership Company (Private Limited) Company (Public Limited)
1.4	Details of proprietor/ partners/Directors.	
1.5	Name of the responsible contact person:	
	Tel No. (O)	
	Mobile No.	
1.6	Date & No of Registration of Firm/company(Attach documentary proof)	
1.7	Permanent Account Number(Attach documentary proof)	
1.9	GST registration Number (Attach documentary proof)	

Signature of the Bidder

FORM 2
FORM OF BID
(In Kerala Stamp paper worth Rs. 200)

To

Date:

The Managing Director
Rubber Park India (P) Ltd.,
2A, "Kautileeyam"
Valayanchirangara P.O
Ernakulam- Pin: 683 556.

Dear Sir,

Sub: Tender for the "Supply, installation, testing and commissioning of LT MCC Panel with Fabricated stand for Pump House including buyback for existing old panel at Rubber Park India (P) Ltd., Irapuram"

Ref: Tender No. RP/E/T-06/R1/2024-2025 date 20/01/2025

I/We have read and examined the notice inviting tender, General Conditions, Technical Specifications in or referred to in the Tender Documents, the receipt of which is hereby duly acknowledged, I/We, the undersigned, offer to supply and deliver goods, in conformity with the technical specifications and the terms and conditions as mentioned in or referred to in the said tender documents for the sum as quoted in the Priced part or such other sums as may be ascertained in accordance with the supply and made part of this bid and the said conditions.

My/Our acceptance to all the conditions of the tender document in this bid form shall persist over any other terms and conditions, deviations, if any, given in my/our bid.

I/We undertake, if my/our bid is accepted, to commence and complete delivery of all the goods and services as specified in the tender document, from the date of receipt of your Work Order/Letter of Award.

If my/our bid is accepted, I/We will submit the required performance guarantee as per the terms and conditions for the due performance of the contract.

I/We agree to abide by this bid for the period of 30 days from the date fixed for bid opening and it shall remain binding upon me/us and may be accepted at any time before the expiration of that period. However, if required, validity of tender period shall be extended by the bidder, on the request of the tendering authority, without any additional financial commitments.

Until a formal contract is prepared and executed, this bid, together with your written acceptance thereof and your Letter of Intent shall constitute a binding contract between me/us.

We undertake that, in competing for (and, if the award is made to us, in executing) the above contract, we will strictly observe the laws against fraud and corruption in force in India namely "Prevention of Corruption Act 1988".

I/We understand that you are not bound to accept the lowest or any bid you may receive.

Dated this.....day of 2024

(Signature)

For and on behalf of

FORM 3
ACCEPTANCE LETTER

To

The Managing Director
Rubber Park India (P) Ltd.,
2A, “ Kautileeyam” Valayanchirangara P.O
Ernakulam- Pin : 683 556

Dear sir,

I/We hereby unconditionally accept the tender terms and conditions in its entirety for Tender No. RP/E/T-06/R1/2024-2025 dated 20/01/2025 for the “Supply, installation, testing and commissioning of LT MCC Panel with Fabricated stand for Pump House including buyback for existing old panel at Rubber Park India (P) Ltd., Irapuram”

Date:
Place:

Signature of the bidder
(With Seal)

FORM 4
DECLARATION FORM

To

The Managing Director,
Rubber Park India (P) Ltd.,
2A, “Kautileeyam”, Valayanchirangara P.O
Ernakulam - Pin: 683 556

DECLARATION

I/We hereby declare that I/We read and understood that Terms & Conditions of contract, Schedule of Requirements etc. for the Tender No. RP/E/T-06/R1//2024-2025 dated 20/01/2025, for the work of **“Supply, installation, testing and commissioning of LT MCC Panel with Fabricated stand for Pump House including buyback for existing old panel at Rubber Park India (P) Ltd., Irapuram”**, and hereby agree to abide by them.

In token of I/We also understand that otherwise this tender is liable to be rejected.

I/We hereby confirm that only the relevant entries asked for, have been made within the Tender documents issued to us. I/We also confirm that in the event of any entry in this tender document, other than the relevant entry, shall make this tender invalid.

I/We hereby confirm that I/We am/are authorized to sign on behalf of the bidder.

Date:

Signature of the bidder
(with Seal)

FORM-6

ARTICLES OF AGREEMENT

Agreement No. RPIPL/E/ /2024-25 Dated / /2024

This AGREEMENT made on this the ...th day of2024, by and between **Rubber Park India (P) Ltd.**, a joint venture of Kerala Industrial Infrastructure Development Corporation (KINFRA) and Rubber Board, incorporated as a company under the Indian Companies Act. 1956, having its registered office at 2 A, "Kautileeyam", Rubber Park, Valayanchirangara P.O, Ernakulam Dist., Kerala Pin : 683 556, duly authorized and represented by its **Managing Director**, Sri., son of , aged (...) years, residing at....., PAN (herein after referred to as 'RPIPL'), which expression shall include, unless repugnant to the context, be deemed to include its successors and permitted assigns on the ONE PART.

And

M/s....., having its registered office at....., Pin:....., duly authorized and represented by its,Sri., son of Sri....., aged(.....) years, residing at”,P O, , Kerala, Pin:....., Aadhaar No.(hereinafter referred to as the “CONTRACTOR” which expression shall, unless repugnant to the context, be deemed to include his legal representatives, executors administrators, successors and permitted assigns) of the OTHER PART.

WHEREAS, RPIPL is desirous of carrying out “.....” hereinafter referred as ‘Work’. WHEREAS, RPIPL has invited competitive item rate tender, on bidders participated in the tender. The price bids were opened on2024 On evaluation, it was found that M/s, has quoted the lowest amount of Rs. (Rupeesonly). Accordingly, RPIPL has issued Work order No., dated awarding the contract to M/s., for the “.....” at his agreed contract amount of Rs...../- (Rupeesonly). The applicable GST will be paid extra.

AND WHEREAS Contractor has agreed to execute upon and subject to the conditions set forth herein and to the conditions set forth in the special conditions, unit rate, specifications / technical specifications & in the schedule of quantities and conditions of contract (all of which are collectively hereinafter to as the said conditions and forming part and parcel of this articles of agreement) the supply/work shown upon the said drawings and/or described in the said specifications and included in the said schedule of quantities at the respective rates therein set forth amounting to the sum as therein arrived at or such other sum as shall become payable there under (hereinafter referred to as the “said Contract amount”).

The following documents and correspondence also form part of this agreement as if they are specifically incorporated herein.

1. Tender document No., dated

2. Negotiation meeting held on.....
3. Work order No , dated

NOW THEREFORE THIS PRESENTS WITNESSED AND IT IS MUTUALLY AGREED AS FOLLOWS:

1. In consideration of the said contract amount to be paid at the time and in the manner set forth in the conditions, the Contractor shall upon and subject to the conditions of the contract, execute and complete the supply in the described specifications and schedule of quantities at the agreed rates.
2. The “RPIPL” shall pay the Contractor, the Contract Amount or such other sum that may become payable at times and in the manner hereinafter specified in the said conditions.
3. The said conditions thereto shall be read and constructed as forming part of this agreement and the parties hereto shall respectively abide by and submit themselves to the said conditions and perform the agreement on their part respectively in the said conditions.
4. The documents mentioned herein above shall form the basis of this contract.
5. The Contractor hereby agrees and undertakes to perform and fulfil all the conditions and obligations connected with the execution of the said contract viz.- “.... ”.
6. The Contractor has furnished 05% of contract value as performance guarantee amounting to Rs./-, in the form of DD in favour of Managing Director, Rubber Park India (P) Ltd payable at Ernakulam, for due performance of obligation of the Contractor under the contract.
7. The “RPIPL” reserves to them the right of omitting any items of work/supply from the contract or having portions of the same carried out by themselves or through any other agency without prejudice to the right of “RPIPL” under this contract.
8. The Contractor shall indemnify and keep indemnified “RPIPL” against all losses and claims for injuries or damages to any person or property whatsoever which may arise out of or in connection with the supply/ work and against all claims, demands, proceedings, damages, cost, charges, expenses whatsoever in respect thereof in relation thereto.

9. It is specifically understood that the Contractor shall not be eligible for or entitled to claim any amount except to the extent allowed or due under the terms of this contract. It should be understood that on no account, the rates once agreed to and quoted in the tender, shall be revised.
10. It is specifically understood that supply/work should be completed in all respects within the stipulated time. Any delay in completing the project in time will attract compensation as per tender condition.
11. The Period of Completion for this supply is 45 days from (ie on).
12. Liquidated damages - @1% per week or part of the week on delay to be computed as per the Tender conditions.
13. The rates quoted by the Contractor shall be firm and there shall be no upward revision of the rates quoted by the Contractor for any reasons whatsoever.
14. It is specifically understood that if any part of the supply/work is not completed in time as agreed by the contractor it will be carried out at the risk and cost of the contractor.
15. The several parts of the contract have been read by the Contractor and fully understood by the Contractor.
16. This agreement has deemed to have come into force from and has validity till actual completion of supply/work, as per tender condition plus defects liability period
17. All disputes arising out of or in any way connected with this agreement shall be deemed to have arisen in Kerala and only courts in Ernakulam shall have jurisdiction to determine the same.

In witness WHEREOF the Managing Director, Rubber Park India (P) Ltd and the CONTRACTOR have set their hands on the day and year above written.

Signed by George V James, Managing Director, Rubber Park India (P) Ltd.	Signed by Proprietor, M/s.
---	---

In the presence of witnesses:

In the presence of witnesses:

Form 7- Form for the Financial Proposal

Financial Bid Pro-Forma

To

The Managing Director
Rubber Park India (P) Ltd,
2A Kautileeyam, Valayanchirangara,
Ernakulam 683 556.

Sir,

Sub: Supply, installation, testing and commissioning of LT MCC Panel with Fabricated stand for Pump House including buyback for existing old panel at Rubber Park India (P) Ltd., Irapuram.

I/We, the undersigned, offer to carry out the Work of **Supply, installation, testing and commissioning of LT MCC Panel with Fabricated stand for Pump House including buyback for existing old panel at Rubber Park India (P) Ltd., Irapuram.** in accordance with your Tender No. RP/E/T-06/2024-2025 dated 20/01/2025. The amount quoted is inclusive of the cost of all parameters linked with the supply/work and all the taxes are cleanly spelt excluding GST.

Sl. No.	Description	Qty	Rate (Rs)	Total Amount excluding GST (Rs)
1	Supply, installation, testing and commissioning of LT MCC Panel with Fabricated stand for Pump House as per the technical specification (Annexure-1) detailed in the tender at Rubber Park India (P) Ltd., Irapuram, dismantling of existing panel inclusive of cost of all materials, consumables, labour, hire charges for all machinery, transportation, insurance charges, all overheads, contingencies, profits, taxes (ie. Income tax etc.), duties/levies, loading and unloading charges etc. complete as per the direction of Engineer in Charge. (Excluding GST).	01 Set		
	Total (Rs.in figures)			
	Total (Rs. In words)			
2	Buy back price for existing panel in pump house From Rubber Park India (P) Ltd, Irapuram in 'as is where is basis' condition (Excl.GST)	01 set		
	Total (Rs.in figures)			
	Total (Rs. In words)			

I/We have read and understood all the terms & conditions attached to this application and agree to abide by it.

Date:

Yours faithfully,

Signature:

Name:

For Office Use

1. *Scorings:*

2. *Overwriting:*

3. *Corrections:*

Signature of the person

Date:

opening the Bid:

Witness: 1. Name:

Signature:

***** End of the Document *****